

High conversion efficiency
High module efficiency to guarantee power output.

0 to +5W

0 to +5W positive tolerance
Detailed information in Electrical Specifications.



Self-cleaning glass
Coating glass for self-cleaning, reduce surface dust.

48

48-hour response service



Outstanding low irradiation performance
Excellent module efficiency even in the weak light conditions, such as morning or cloudy.

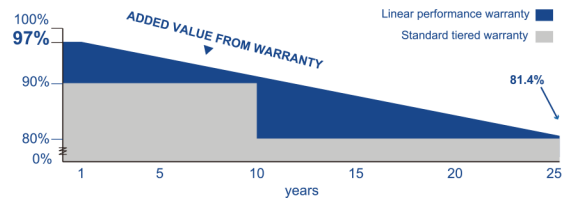

Excellent loading capability
2400Pa wind loads, 5400Pa snow loads.

25

25-year performance warranty

10

10-year warranty on materials and workmanship



ELECTRICAL DATA

Model Type PiK 440-460M (120) W	440	445	450	455	460
Peak Power (Pmax)/W	440	445	450	455	460
Module Efficiency/%	20.33	20.56	20.79	21.02	21.25
Maximum Power Volage (Vmp)/V	34.20	34.50	34.70	34.90	35.20
Maximum Power Current (Imp)/A	12.84	12.90	12.96	13.02	13.08
Open Circuit Voltage (Voc)/V	41.00	41.20	41.40	41.60	41.80
Short Circuit Current (Isc)/A	13.58	13.63	13.68	13.73	13.78
Power Tolerance			0 to +5W		
Maximum System Voltage			1500V		
Nominal Operating Cell Temperature			41±3°C		
Maximum Series Fuse Rating			25A		

MECHANICAL DATA

Cell Type	Mono, 182mm, 10BB
Number of Cells	120 cells(6x10+6x10)
Weight	23.5kg
Dimension	1909x1134x30mm
Max Load	5400 Pascals
Junction Box	IP68 rated
Connector	MC4 Compatible
Wire Type	PV Wire

TEMPERATURE CHARACTERISTICS

Temp. Coeff. of Isc (TK Isc)	0.05% /°C
Temp. Coeff. of Voc (TK Voc)	-0.28% /°C
Temp. Coeff. of Pmax (TK Pmax)	-0.36% /°C

PACKING MANNER

Container	40' HQ
Pieces per Pallet	36
Pieces per Container	(36+36)x12=864

PHYSICAL CHARACTERISTICS

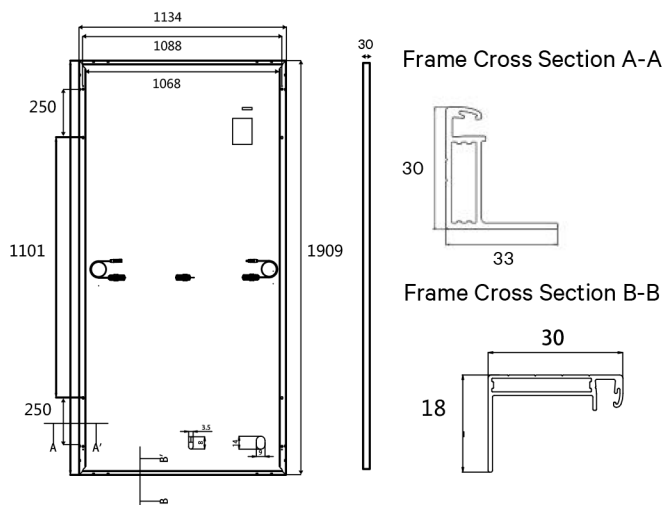

ELECTRICAL CHARACTERISTICS

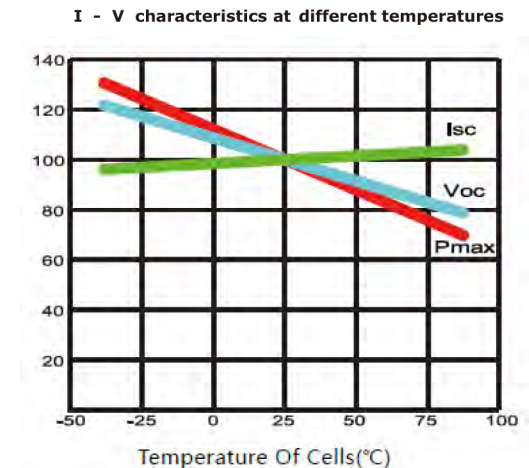
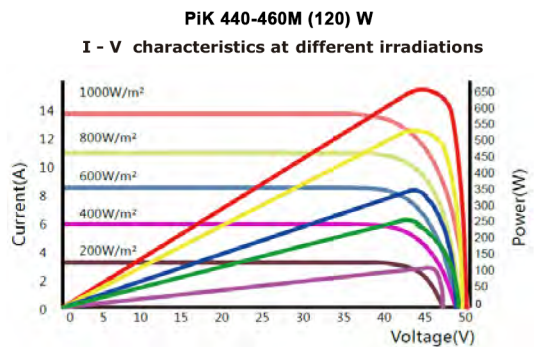

Note: the specifications are obtained under the Standard Test Conditions (STCs): 1000W/m² solar irradiance, 1.5 Air Mass, and cell temperature of 25°C. The NOCT is obtained under the Test Conditions: 800W/m², 20°C ambient temperature, 1m/s wind speed, AM 1.5 spectrum. Please contact contact@pikcellgroup.mk for technical support. The actual transactions will be subject to the contracts. This parameters isfor reference only and it is not a part of the contracts. The specifications are subject to change without prior notice.